

HZG Dry Type AC Hipot Tester



Dear user:

Thank you for choosing HZGDry Type AC Hipot Tester.

We hope that this instrument can make your work easier and more enjoyable, so that you can get the feeling of office automation in the test and analysis work.

Before using the instrument, please read this manual, and operate and maintain the instrument according to the manual to prolong its service life. "Just a light press, the test will be completed automatically" is the operating characteristics of this instrument.

If you are satisfied with this instrument, please tell your colleagues; if you are not satisfied with this instrument, please call (0312) 6775656 to tell you to serve you at all times-Baoding Huazheng Electric Manufacturing Co., Ltd., our company will definitely make you satisfied !

Contents

Dry Type Testing Transformer.....	1
I.Product Introduction.....	1
II.Technical Target.....	1
III. Major Technical Parameters.....	1
IV.Operating Principle.....	2
V.Methods Of Application.....	3
VII.Accessories.....	6
HZXC HV Hipot Control Unit.....	7
HZTC HV Hipot Control Unit.....	9
I.Outline.....	9
II.Main Characteristics.....	9
III.Panel Introduction.....	10
IV.Technical Parameter.....	11
V.Connection Wire Sketch Drawing Of It And High Voltage Test Transformer.....	11
VI.Manual Explanation.....	12
VII.Usage And Maintenance.....	12
VIII.Supplementary Explanation.....	13
IX.Electrical Schematic Diagram.....	14
Packing List.....	15

Dry Type Testing Transformer

I.Product Introduction

This series transformer uses advanced production equipment, and new technology of coil winding epoxy vacuum pouring and CD-type iron core, which obviously reduce weight and volume, improve insulating strength and humidity resistance level, effectively weaken leakage magnet resulting in greatly enhance the ability to withstanding impact of testing short circuit current of transformer.

This series products have features of light weight, small volume, beautiful appearance, stable performance, convenient usage and carrying, especially suitable for site operation, are new generation high voltage testing transformer used for AC and DC in China. This series products are applicable to power system and all power users to detect on site the insulating performance test of all electrical equipment, high voltage power sources of all appliance's voltage system or equipment with DC high voltage small current.

II.Technical Target

1. Impedance voltage: 4.5% - 8 %
2. Output voltage wave form: sine wave
3. Surface temperature rise: < 55 °C
4. No-load current : < 4 %
5. Allowable continuous operation time: 1 hour

III. Major Technical Parameters

Capacity (KVA)	Input voltage (V)	Output voltage (KV)	Output current (mA)	Output DC high voltage (KV)	Max. External dimension (mm)	Weight (kg)
1.5	200 (400)	50	30	70	230x180x370	13
3			60		310x250x570	30
6			120		300x310x680	46
10			200		320x350x720	73

20			400		360x350x720	85
30			600		500x380x780	120
5		100	50	140	360x350x960	80
10			100		360x350x960	80
20			200		500x380x880	120
30			300		580x380x880	160
50			500		650x460x1010	230

Remarks: Products can be manufactured according to the parameters provided by customers.

IV.Operating Principle

Input voltage of this series products is 200V, using principle of electromagnetic induction and changing input voltage according to demand to make output high voltage continuously adjust from 0V to rated maximum value.

When DC withstand voltage and leakage current testing are conducted, the input voltage can be changed as long as high voltage silicon stack is rotary installed at high voltage output terminal resulting in achieving DC high voltage output with different value.

For detailed working principle of this series products see Figure (1), if used as cascade, its wiring see Figure (2).

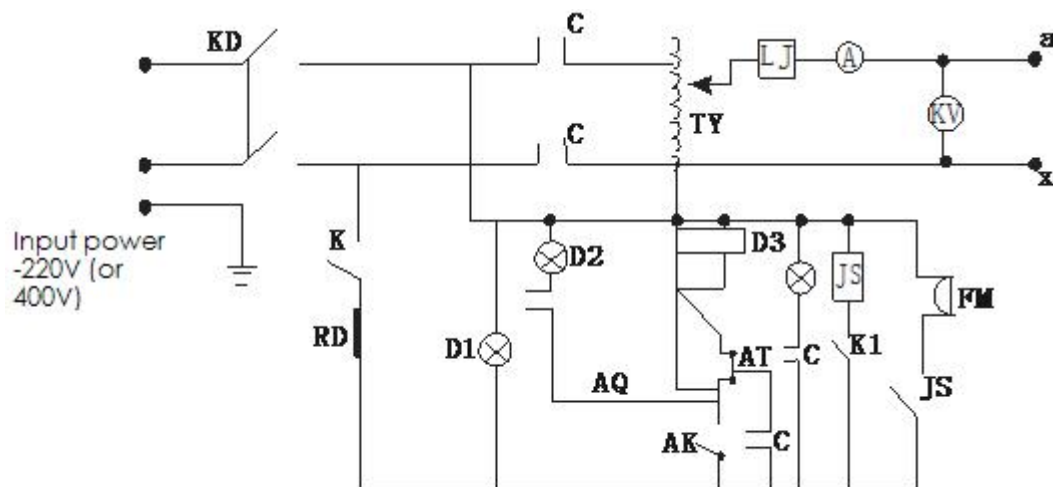

Figure (1)

- | | |
|---|-------------------------------|
| GYD:Testing transformer | JS:Time relay |
| TY:Self-adjusting voltage regulator | FM:Alarm equipment |
| LJ:Over-current relay | D1, D2 and D3:Indicator light |
| C:AC contactor | RD:Fuse |
| K:Main power switch | K1:Power switch of time relay |
| AK:Zero limit switch of voltage regulator | AQ:Start button |
| CL:High voltage silicon stack | AT:Stop button |
| A:Output ammeter | KV:Output voltmeter |

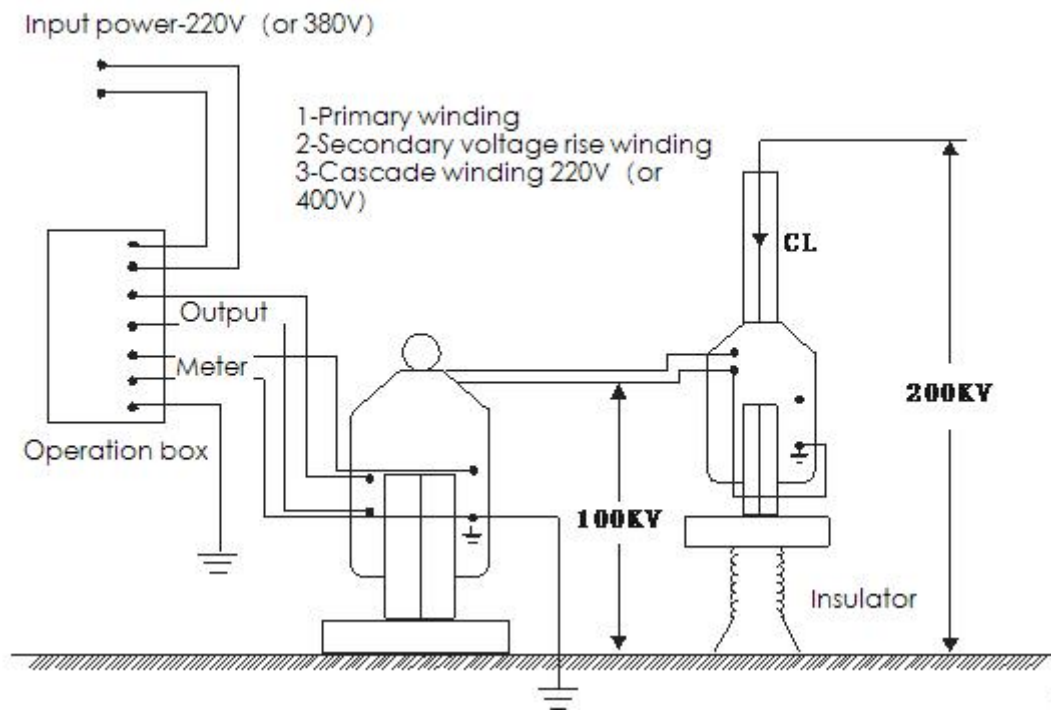

Figure (2)

V.Methods Of Application

- (1) Before testing, “ the shell terminal of high voltage testing transformer ” and “ grounding terminal of power control box ” must be properly grounded, otherwise, it will be harmful to personal and equipment safety.
- (2) Before operation, users must be aware of the electric principle wiring diagrams of

high voltage testing transformer and power control box. During checking DC withstand voltage and leakage testing, high voltage silicon stack or microammeter can be suspended at high voltage terminal of high voltage testing transformer.

- (3) When preparation is ready and the circuit is right after checking, the main power can be closed, the red switch indicator light is also on at this time. If the light is not on, handle of voltage regulator should be turned back to zero position at anticlockwise direction. The indicator light on red stop button is on, otherwise start button will refuse cooperation.
- (4) Pressing start button, the indicator light of green button will turn on, at this time, evenly and slowly turning handle of voltage regulator clockwise at the speed of 1.5-2KV/s. Make high voltage gradually rise and paying close attention to indication and testing products of ammeter until adjust the high voltage required by test.
- (5) The withstand testing time for the testing products can be set by toggle timer, then pressing time and alarm switch, i.e. Testing product's withstand voltage in specified time, then informing by alarm. If the testing products are punctured, over-current relay will trip automatically, the ammeter value will read number at this time, the number is the value of puncturing voltage by products.
- (6) If the testing products need protection are punctured, discharge voltage of protective ball can be adjusted to about 1.15 times that of testing voltage at continuous protective ball's gap on high voltage side.
- (7) Schematic Diagram for High Voltage Testing:

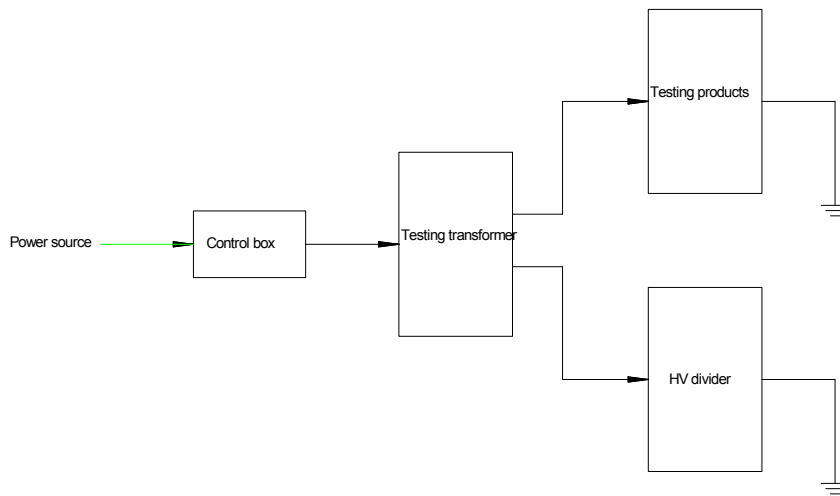

VI.Precautions

1. The insulating testing products of high voltage appliance should be safe and correct. In addition to know well the manual of this product, the operation must be implemented in accordance with relevant national standards and plans: GB/T16927-1996 High-Voltage Experimentation Technology and DL/T596-1996 Preventive Testing Regulations for Electrical Equipment.
2. Due to the design characteristics and structure limitation of this series products, continuous operation under rated output capacity should not exceed 2 hours. If the products need to be used again, the power can be connected until power off for 2 hours. Continuous operation can be done under two thirds of rated voltage and two thirds of rated current.
3. In normal insulation of high voltage appliance, this series products are not allowed to operate in case of exceeding rated output voltage.
4. When this series products consist of cascade high voltage test, users should pay special attention to check the correctness of conditions and wiring of Class 2 and 3 transformer's main body and insulating bracket, as well as the protective grounding

of entire system and conditions of protective grounding.

VII.Accessories

Manufacturer Certificate

Operation Manual

HZXC HV Hipot Control Unit

Control Box(≤10KVA)

If the capacity of main control box is not more than 10KVA the panel of the main control box is as figure 4.



Figure 4 Panel of main control box

The operation of the insulation test with HZG series HIPOT tester is as follow:

- 1) Please make grounding connection for sample object, HV transformer and main control box first
- 2) Please discharge the sample object if the sample object is a capacitive equipment.
- 3) Please make connection for tester and sample object according to figure 3.
- 4) Please make power connection for main control box.
- 5) Confirm the high voltage value in withstand.
- 6) Setting the protection value of current by the pointer on the over current protection relay panel.
- 7) Adjust the regulator to zero position and then press down the close button on the panel the tester with enable the high voltage output unit.

- 8) If the regulator is not at zero position when you press down the close button the high voltage output unit would not be enabled. There is a zero position indication lighter on the panel of the main control box.
- 9) Adjust the high voltage output to the withstand test value step by step. Read the high voltage value and LV current from meters at the same time.
- 10) Start the timer by the timer switcher on the main control box panel when the high voltage has.
- 11) If the current over the value set on the panel of the over current relay the tester would cut off the power supply of HV transformer immediately. It is said the test result is failure.
- 12) If the timer display value reach the set value the tester would have a sound alarm to inform operator that the withstand time is ok. If the tester has not start the over current protection unit before sound alarm it is said the test result is ok.
- 13) Open the power supply of HV transformer by press down the “open” button on the panel of the main control box when test is end.
- 14) Please discharge the high voltage circuit of sample equipment before remove off the cable connection of high voltage circuit.

Please do not start the test if some part of the tester had been destroyed.

HZTC HV Hipot Control Unit

I.Outline

HZTC series control station is a complete set of equipment of high voltage test transformer, it and the test transformer carry out resistance pressure and leakage test. This product is in according with electric industrial standard DL/T848.2-2004.

II.Main Characteristics

This series product has characteristics, such as beautiful appearance, small volume, light weight, simply operation and conveniently maintenance.

This series control station is consists of touch type voltage adjustor and circuit on control, measure and signal. After goes through work frequency power 230V/400V, adjust the output voltage of voltage adjustor(namely the input voltage of test transformer), then accept the required test high voltage(the pressure value which is tester) , which work principle is as the follow drawing.

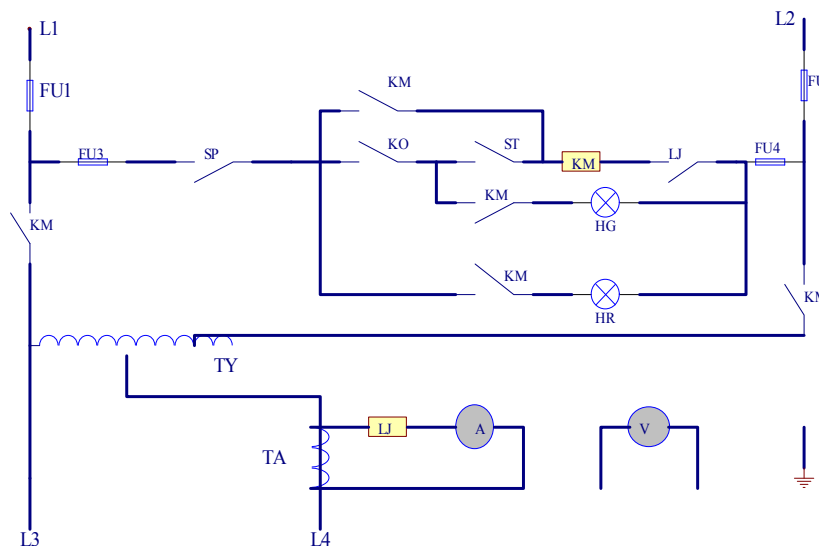

KM	AC Touch Machine	HG、HR	Indicator	TY	Auto Voltage Adjustor
LJ	Current Relay	TA	Current Mutual Inductance	KO	Zero Switch

III.Panel Introduction

Series Controller($\geq 10\text{KVA}$)

If the capacity of main control box is over 10KVA the panel of the main control box is as following:

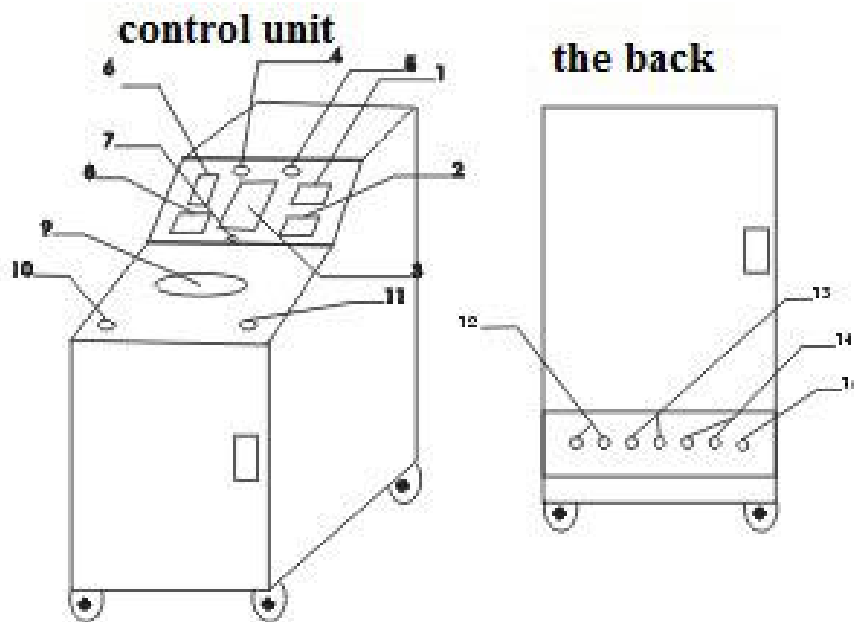

- 1、 HV voltmeter (KV) 2、 LV ammeter (A) 3、 Over current protection setup

- 4、 Power
- 5、 Operate
- 6、 Withstand voltage time setup
- 7、 Timer
- 8、 Over current protection ratio(×1, ×2,OFF)
- 9、 Handle of voltage regulator
- 10、 Start
- 11、 Stop
- 12、 Power Input 220V/380V
- 13、 Output 0~250V/430V
- 14、 Meter
- 15、 Grounding

IV.Technical Parameter

Model	Power			Output	
	Phase Value	Voltage (V)	Frequency (HZ)	Voltage (V)	Current (A)
HZTC-10	1/2	230/400	50	250/430	28/16.3
HZTC-15	2	380	50	430	23.3
HZTC-20	2	380	50	430	32.6
HZTC-30	2	380	50	430	46.5
HZTC-50	2	380	50	430	69.8

V.Connection Wire Sketch Drawing Of It And High Voltage Test Transformer

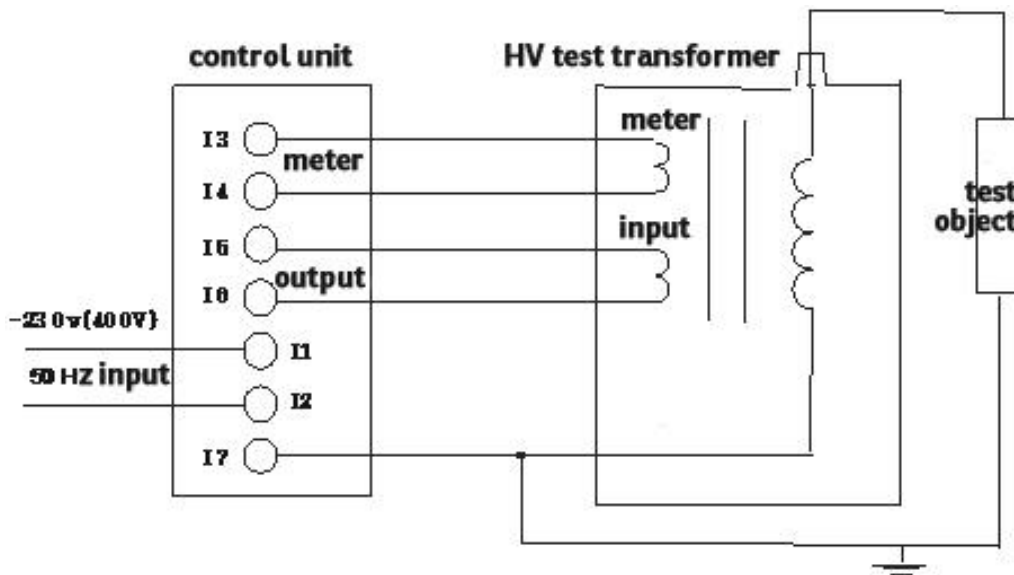

VI.Manual Explanation

1. As the table shows, please connect the control station with the test transformer, also please do not forget to connect with the floor line. After careful examination, you can make electricity go through it.

2. When the electricity goes through, please turn the voltage adjustor to Null, Zero Switch turns on and the signal turns on too(which indicate that the output of the voltage adjustor is Zero).

3. Press the Start Button, connect with touch machine, and plug the voltage adjustor in, at the same time, the power signal light will turn off, but working signal light will turn on.

4. Whirl the voltage adjustor slowly and clockwise, and read carefully the voltage meter, when it reaches the required voltage, please stop whirling and change the opposite direction to whirl until it reaches back to Zero.

5. After the examination, please press Stop Button, to shut off the touch machine, and the working signal light will turn off, but the Zero Signal Light will turn on.

6. This equipment is installed with over-current protection. Over-current relay should be chosen when you get the data by examination. But the relay always is setting to be 80% of the rated data. When it look a little over-loaded, please reset it according to the loaded current, to guarantee the safety of this equipment. During the voltage is becoming higher and higher, this experimental equipment will be proved not to be qualified if it becomes short-current, over-loaded relay, and the power were shut down. When it happens, you should whirl the adjustor to Zero Level.

VII.Usage And Maintenance

1. When you open the box, you need to check whether it's in good condition or not, especially you need to check whether the connection ports become loose or not, and the carbon brush connects with the voltage adjustor well or not.

2. Strictly follow the procedure, please read the manual first.
3. If it has been not in use for a long time, you should check main circuit floor insulating resistance by 2500V MΩ meter, and the data should not below 1.5MΩ.

VIII. Supplementary Explanation

HZTC series control station is another set of equipment of light test transformer, it has characteristics, perfect capacity, beautify appearance, small volume, light weight, beside, also has the function of switch on and timing, which manual explanation is same as TC control station.

- 1、 Over-current rated value= Over-current relay dial reading $\times K$

Among which, K is as a state value of change/excise (-SA) switch of current power, respectively for as 1, 2, ∞., K of the switch in $\times 1$ 、 $\times 2$ shift is as 1 and 2 respectively, excise shift is as $+\infty$ (in normal condition without using it to avoid damaging the equipment due to lost the protection for transformer.

- 2、 Electric control station is normally above 30KVA. As for client convenience, it adopts the methods of increasing voltage, decreasing voltage. The method of voltage increasing is same as manual, firstly fast, secondly slow. When the required voltage of increasing voltage is coming, don't press the button forever, it'd better loose a little (press and loose by turns). During the voltage decreasing, press the button of decreasing voltage until charcoal brush back to zero, then the zero signals light is on, you can press the button of stop. Finally, shut off the general switch (air switch).

- 3、 Panel drawing of control station and connection drawing, see the annex.

- 4、 This control station could measure the high voltage leak current of the tester. Please measure the high voltage leak current after accomplish the test of the AC voltage during in using to prevent occurring short circuit phenomenon and produce high voltage which exist dangers for operator. The specific procedure is as following:

First, connect the back connection board of the control station in specific wire, and then carry out the AC voltage test. Second, link the high voltage end part of the control station and test transformer (see the wiring sketch drawing in the next page) namely could

read the value of the high voltage current.

IX. Electrical Schematic Diagram

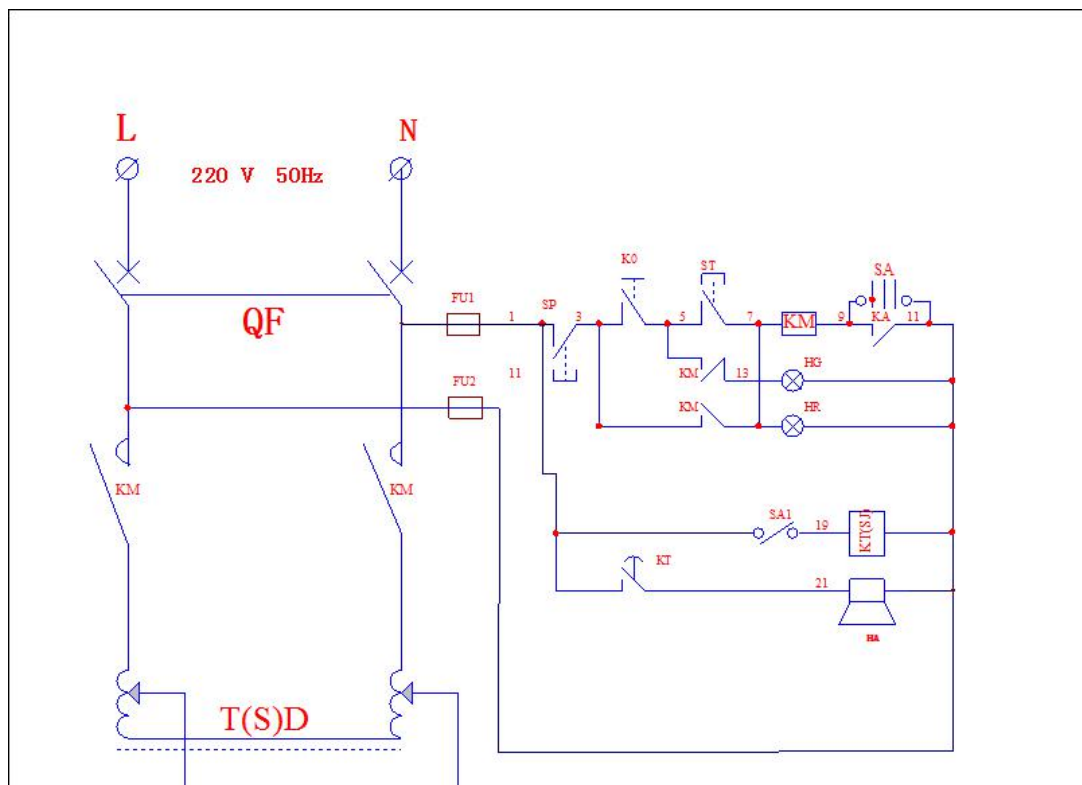

Packing List

No.	Item	Qty
1	Main engine	1
2	Control Box	1
3	Power line	1
4	Test line	1

