

HZYA-3Z On-load Tap-changer Tester



Contents

I.Description.....	1
II.Features.....	1
III.Technical Parameters.....	1
IV.Application Conditions.....	2
V.Panel Introduction.....	2
VI.Instructions.....	3
VII.Switch Action Principle And Waveform Analysis.....	8
VIII.Packing List.....	11

I.Description

The on-load tap-changer is the only moving part connected to the transformer circuit. Therefore, the detection of the on-load tap-changer is becoming more and more important. In the "power equipment transfer and preventive test procedures", asked to check the on-load tap-changer action sequence, measurement switching time. The instrument is mainly used to measure the transformer on-load tap-changer transition waveform, transition time, the instantaneous transition resistance, three-phase synchronization and so on.

The instrument is highly intelligent, all Chinese menu prompts, simple operation. Instrument small size, light weight, anti-interference ability, greatly reducing the labor intensity of the site staff, is the power supply units, transformer manufacturing industry to ensure safe production, improve product quality ideal instrument.

II.Features

- Large output current, light weight;
- Test YO, Y, Δ type transformer, the resistance unnecessary to be converted but directly display;
- With winding or without winding measurement;
- Waveform display automatically adjusts the resistance according to the sampled value, the time value amplitude
- With perfect protection circuit, reliability and strong;
- 7-inch large LCD display, easy on-site operation;
- Built-in high-capacity lithium battery(optional)
- 500 sets of data can be saved in Internal automatically, can connect with U Disk.

III.Technical Parameters

Output current: 2.0A、 1.0A、 0.5A、 0.2A

Measuring range Transition resistance: 0.5 Ω ~5 Ω (2.0A) 2 Ω ~20 Ω (1.0A)

5 Ω ~40 Ω (0.5A) 20 Ω ~100 Ω (0.2A)

Transition time: 0 ~ 320ms

Open circuit voltage: 24V

Measurement accuracy Transition resistance: $\pm (5\% \text{ reading} \pm 0.1\Omega)$

Transition time: $\pm (0.1\% \text{ reading} \pm 0.2\text{ms})$

Sampling rate of 20kHz

Storage mode U disk storage

Dimensions: 340mm × 245mm × 210mm

Instrument weight: 7kg

IV.Application Conditions

Ambient temperature -10 °C ~ 50 °C

Ambient humidity $\leq 85\% \text{ RH}$

Power supply AC220V $\pm 10\%$

Power frequency 50 $\pm 1\text{Hz}$

V.Panel Introduction

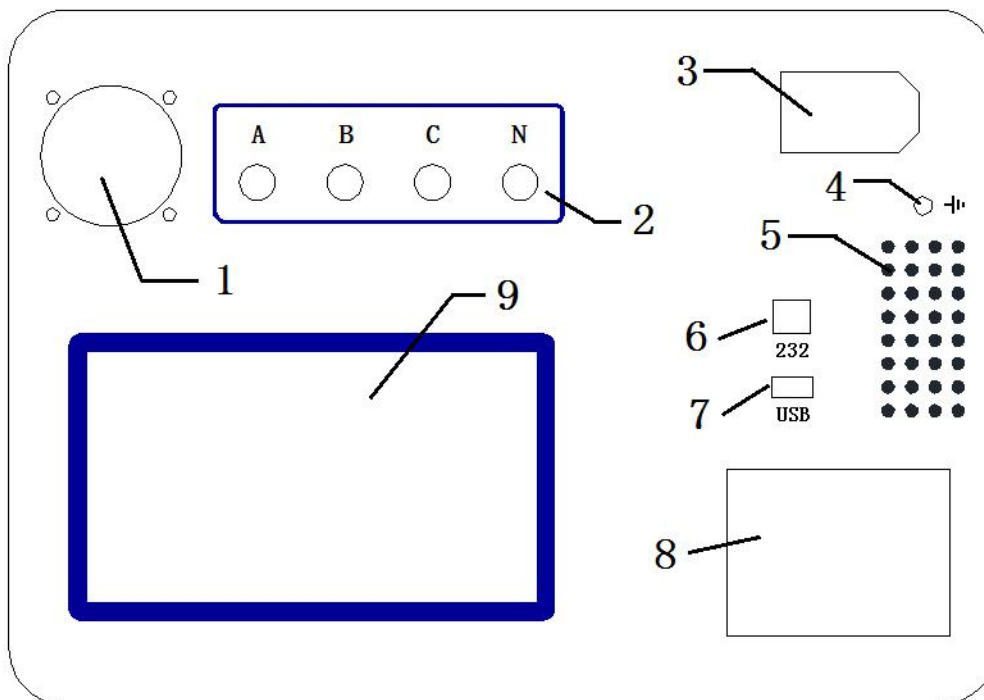

Figure 5.1 panel diagram

- 1.Fan: Air outlet
- 2.A, B, C, N correspond to the A, B, C,N of the transformer respectively.
- 3.AC220V: power input port of the machine, with AC socket, Fuse holder and switch.
4. Earth terminal: for the whole machine housing grounding, belonging to earth protection.
5. Heat sink.
6. 232 Port
- 7.USB
8. Printer: High-speed printer, print test results.
9. Monitor: 7inch Highlight LCD display.

VI.Instructions

Precautions for operation:

- Before use, the grounding terminal of the instrument must be connected to the ground wire.
- During the test, the test line is not allowed to be removed.
- With the winding test, the transformer non-test side should be three-phase short-circuit ground.
- For a long time without moving the switch, the test should be repeated before the switch, remove the contact surface of the oxide layer and impurities

(1) With winding test method

1. Remove the three-side lead of the transformer under test, the non-test side (usually the MV side, LV side) were three-phase short-circuit ground. The test clamp yellow, green, red and black were clamped to the measured side of the transformer (usually HV side) casing A, B, C three-phase and neutral point, and then the other end of the test line yellow, Green, red and black lines are connected to the A, B, C, N terminals of the instrument. The following figure shows the different types of transformer wiring:

Wiring method: YO type

Wiring method: Y type

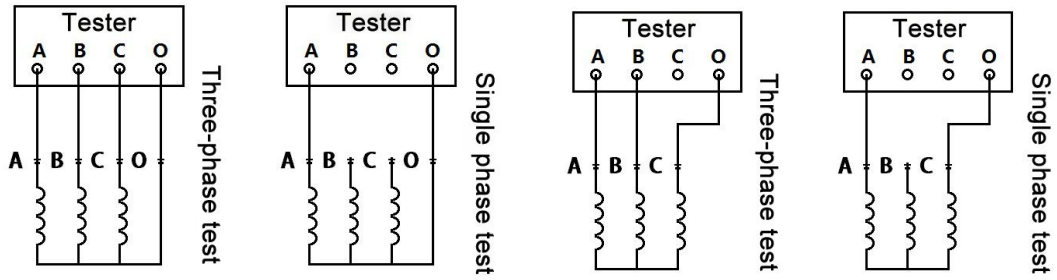

Wiring method: Δ type

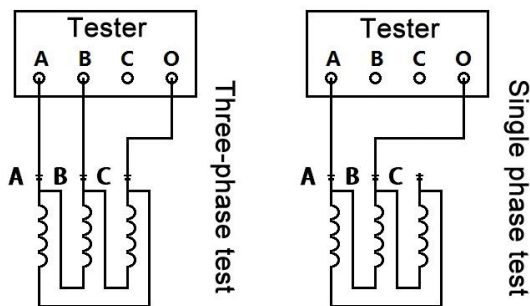

2. Confirm the above wiring is correct, the boot, the instrument after the self-test settings interface, as shown below: Δ

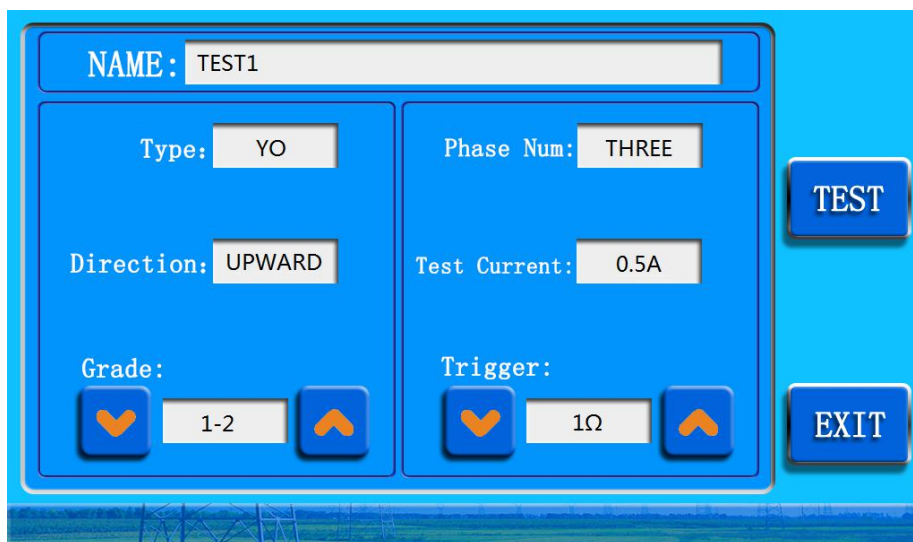

Name: Test name (up to 16 characters)

Shift Direction: set up shift, or down shift

Measure the number of phases: set single-phase measurement, three-phase

measurement

Wiring Type: set YO type, Y type, Δ type

Charging Current: select 2.0A, 1.0A, 0.5A, 0.2A 4 current stalls

Measuring Range: 2.0A (0.5 Ω ~5 Ω)

1.0A (1 Ω ~ 20 Ω)

0.5A (5 Ω ~ 40 Ω)

0.2A (20 Ω ~ 100 Ω)

Stalls: 00-95

Trigger Resistance: pre-test to test the transition resistance value, select the appropriate trigger resistor, in order to accurately measure the trigger value as a result of the transition resistance value of about 1/2

Click on the corresponding input box, modify the corresponding project, set up, press the "start test", enter the test state, The screen is shown below

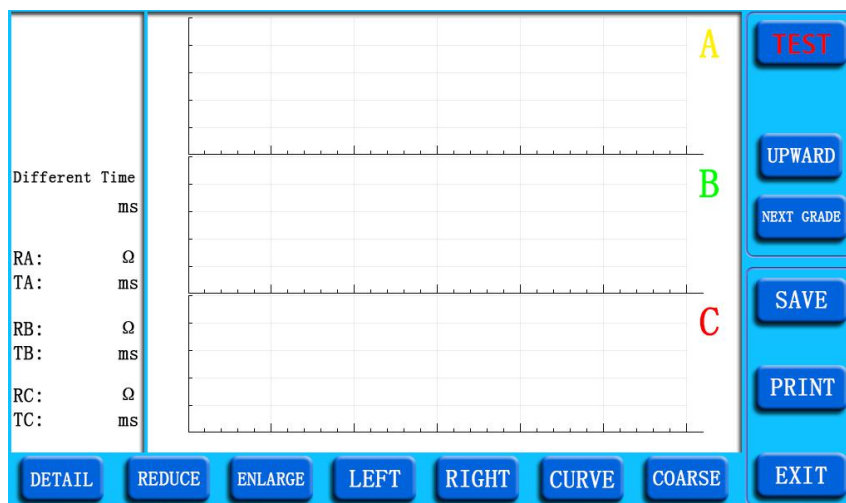

The three curve changes according to the test data. Because the instrument has a charging process for the winding and switches, so the curve will change from small to large, until the three-phase curve are stable, press the "start test", then manual or electric operating mechanism (please after the start of the measurement In order to protect the device, every time the output current is measured for 2 minutes, more than two minutes, the output is automatically stopped and switched back to the parameter setting interface.)

After the operation is completed, the LCD automatically displays the action waveform, Button at the bottom of the screen, you can adjust the curve magnification, left to right to move, easy to view the waveform.

Press the first gear, automatically switch to the next gear, press the "start measurement" to start a new test;

Save: store the data in memory.

Print: Prints the test data waveform

(2) No winding test method

Connect the test line yellow, green, and red test clamps to the voltage regulator X1 (A1), Y1 (B1), Z1 (C1) and short routes are received to the corresponding X2 (A2), Y2 (B2), Z2 (C2), the black test clamp to the neutral point, the remaining steps with the same winding test steps. With the winding test compared with no winding test, the former action time is long, about 3-7 ms.

For example: no winding test 4 points connected to 5 tap the switch operating waveform wiring method (see Figure 6.5)

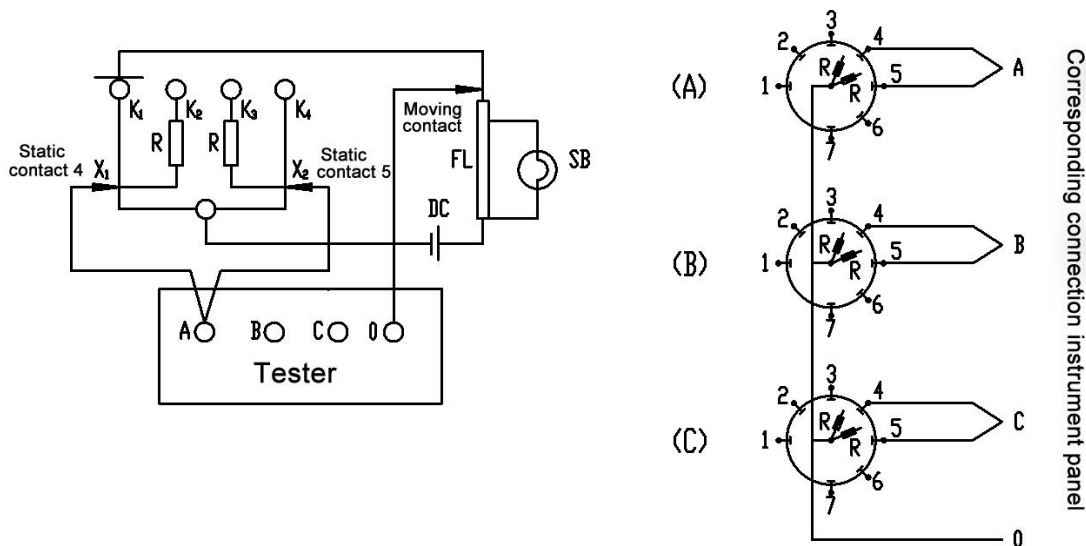

Note: A, B, C, three phase moving contacts are shorted to the neutral terminal of the instrument

(3) The test method of transformers without voltage difference at the neutral point of Y type of voltage regulating side winding

This structure of the test sample in the case of no hanging core, the neutral point can not lead, but every two-phase test, Such as measuring A, B two-phase, wiring method shown as Figure 6.6, the C as a neutral point, the operation steps and the same with the winding test method, Only in the LCD screen at a time to display only two sets of waveforms and data, data analysis and the neutral point of the transformer derived from the same analytical method, but the transition resistance value needs to be converted: Let the measured value be R' , the actual value is R , then the two-phase measurement $R = 1 / 3R'$ (such as single-phase measurement when $R = 1 / 2R'$). After A, B phase after the test, you can then A as a neutral point, measure B, C phase, or B as a neutral point, measuring A, C phase. The wiring method and data analysis are the same.

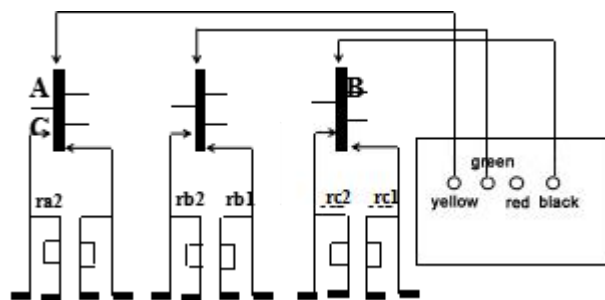

4) Test method for transformers with voltage regulating side winding Delta connection:

Test connection method as in Figure 6.6, the same test analysis method and other transformer operating procedures and data, just need to set the transition resistance value conversion: measured value is R , the actual value is R , when $R = R$, two-phase flow measurement, phase measurement $R=2/3 'R'$.

(5) Data query interface

Press the data query button, enter the data query interface, as follows:



Press the "display waveform" to display the waveform data, and consistent with the measurement interface, please refer to the measurement Waveform Interface

(6) System settings interface

Set the system variables at the system settings interface, as shown below:

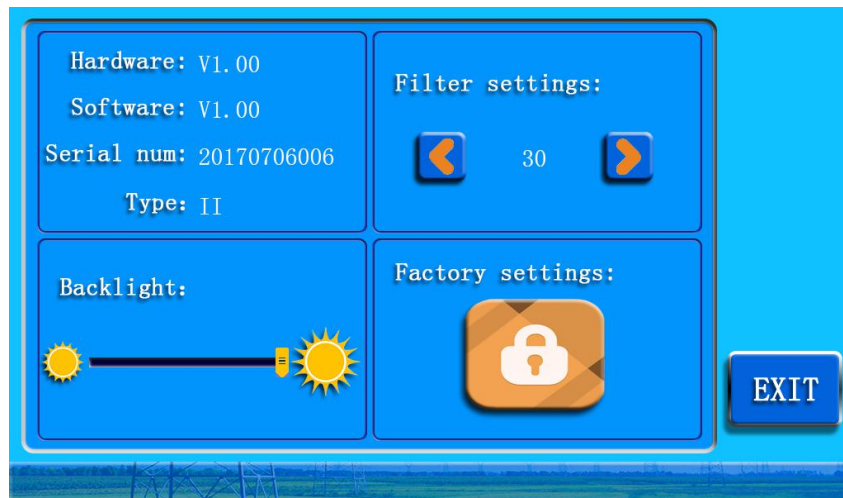

Filter settings: set the filter level of the test waveform, 0-60, preset 30;

Backlight settings: LCD backlight;

Clock setting: set time, date;

Instrument introduction;

VII.Switch Action Principle And Waveform Analysis

1) Switch action principle:

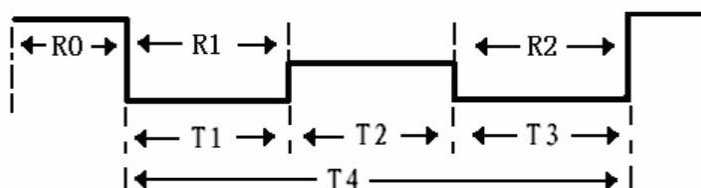
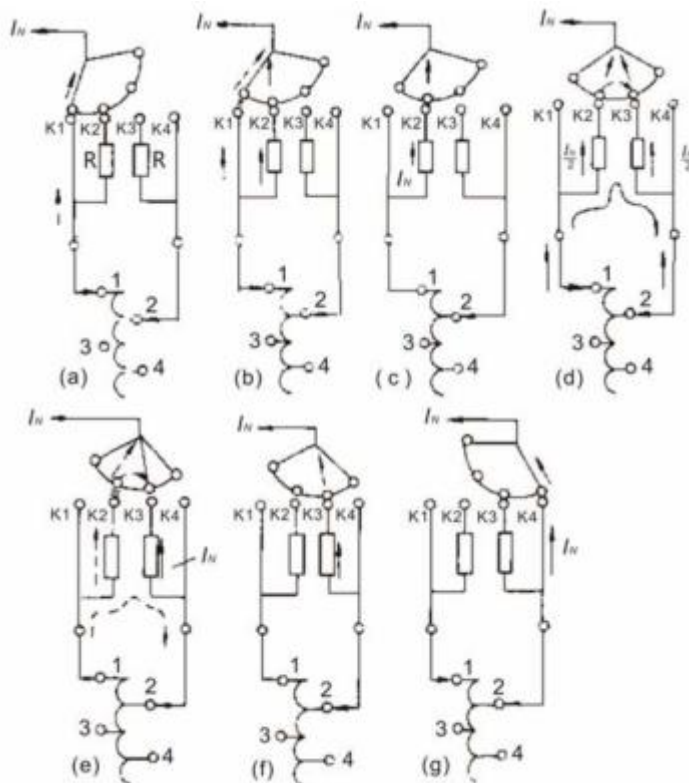

The tap switch is operated according to the order of a-g, and normal actions are generated standard waveform as following shown:

R0: Coil resistance and test line resistance

R1: 1 Transition resistance 1

R2: Transition resistance 2

T0: Three phase synchronization (based on the earliest detection of the switching phase)

T1: Run time of Transient resistance 1

T2: Bridging time

T3: Run time of Transient resistance 2

T4: Transit time

2)Waveform analysis:

1.

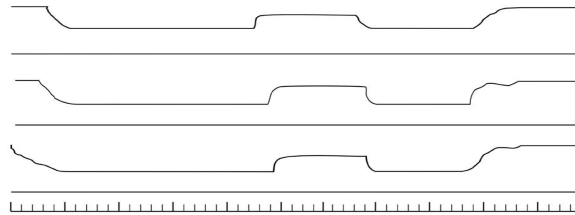

As see from the figure above, the time before the bridge is too long has reached 50ms (three times the normal time), and not just a phase, but three-phase almost. This is typical fast aging of mechanism energy storage spring, slow down.

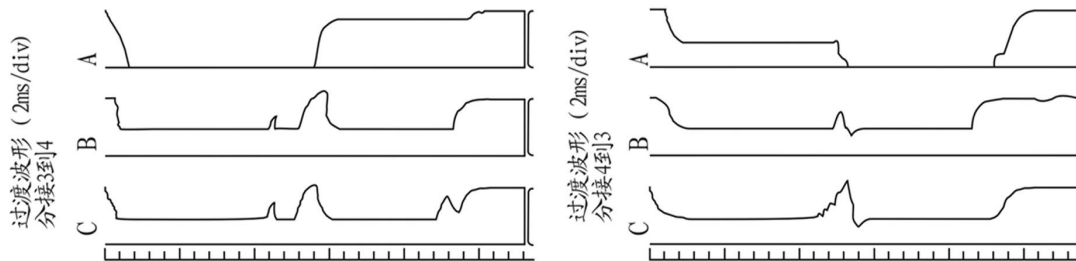

As can be seen from the figure above, the transition has symmetrical zero crossing segments from single to double (3-4) and double to single (4-3), at the singular side, and the transition resistance is observed from the instrument much larger than 50Ω (more than 50Ω can be considered as an open circuit). This is typical of transition resistance defects. After checking, it is found that the transition resistance on the singular side has been broken.

3.

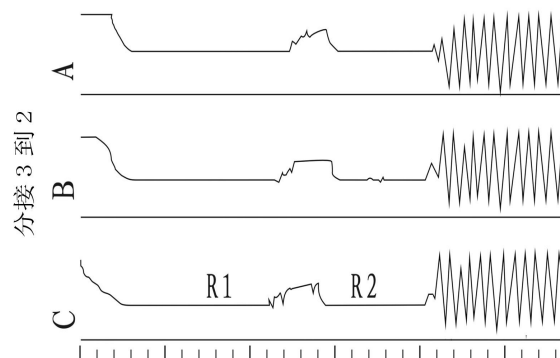

This waveform in the above figure is due to higher sensitivity at testing begins, It is also caused by 3-2 directions (increasing inductance) that can cause shock.

Properly reduce sensitivity from 1-n direction, test results are normal.

4.

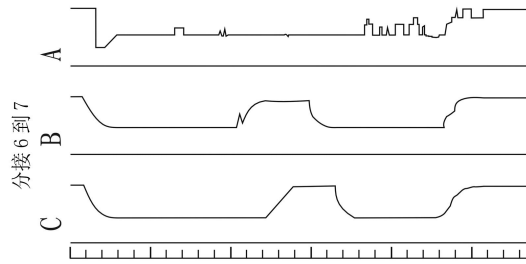

As shown in the figure above, the A phase waveform is chaotic, and the transition resistance value is only 0.3-0.5Ω, and it is also same from 1-7. The hanging check found that the soft wires from A phase switch are broken, which causes the A phase transition resistance to be shorted (not dead). After field processing, the waveform is normal.

VIII.Packing List

No.	Item	Qty
1	Main engine	1
2	Short test line	4
3	Test line	4
4	Power line	1
5	Ground lead	1